

**CIRCULAR DESIGN AND
MANUFACTURING TECHNIQUES
FOR NEXT-GENERATION
HIGHLY-EFFICIENT INTEGRATED
AXIAL FLUX MOTOR DRIVES
FOR ELECTRIC VEHICLES**

Newsletter M29 (May 2026)



Funded by
the European Union

Electric traction motors are at the heart of the transition towards a zero tailpipe emission road mobility landscape, with their performance and cost directly impacting the attainable market penetration of electric vehicles (EV). To accelerate the transition, next-generation electric motors need to push the existing boundaries in terms of efficiency, power density, manufacturability, cost, and environmental sustainability. A reduced and more circular use of rare earth resources is critical to reinforce Europe's strategic autonomy and establish a more economically sustainable value chain. Recently developed axial flux motor technology based on a yokeless and segmented armature topology yields promising prospects in all these areas, significantly reducing the required amount of rare earth magnet material by design, and combining this with unmatched power density compared to state-of-the-art radial flux machines.



OUR MISSION

- **Range improvement and cost reduction**
Increased EV acceptance is an essential step towards zero emission.
- **Innovation in design and manufacturing**
With improved thermal behaviour and the use of novel materials, a higher power density can be achieved and simultaneously circularity, recyclability and cost competitiveness are boosted.
- **Enhancing capability of the electrified drivetrain**
The CliMAFlux on-board motors are integrated with the PE inverter and mechanical transmission systems and managed by robust predictive controllers based on digital twins, including AI prediction models.



- Call: HORIZON-CL5-2022-D5-01-09: Nextgen EV components: High efficiency and low cost electric motors for circularity and low use of rare resources (2ZERO)
- Budget: €4.307.309,55
- Starting date: 1 January 2024
- Project duration: 45 months^a
- Project coordination: Ghent University
- 11 partners from 6 countries

^aA nine-month extension of the originally 36 month project was recently approved.

TRAXIAL BV

KORTRIJK, BELGIUM

TRAXIAL
A MAGNAX COMPANY

Last year's major milestone was the successful design and assembly of our new motor for the Integrated Drive Unit (IDU).

The prototype was fully built and tested in-house and passed initial performance validation.

Testing confirmed that the motor meets its ambitious targets for continuous power density, achieving at least 23 kW per liter and 7 kW per kilogram.

These results demonstrate that the motor delivers exceptional power in a compact and lightweight package, which are key characteristics for improving efficiency and vehicle performance on a system level.

With this achievement completed, the team now looks forward to the full integration with the BLUWAYS inverter and STARD gearbox, followed by installation in the test vehicle.



IDU motor KPIs:

- ☑ 50% cost reduction
- ☑ >23 kW/L continuous power density
- ☑ >7 kW/kg specific power
- ☑ Reduction of energy loss > 60 Wh

GHENT UNIVERSITY

GHENT, BELGIUM



AXIAL FLUX MOTORS WITHOUT CRITICAL MATERIALS

The current generation of axial flux machines relies on rare-earth permanent magnets (PM) on the rotor discs and copper in the stator windings. The chemical elements used in rare-earth magnets such as neodymium, dysprosium, and samarium are globally recognized as critical materials. In addition, copper is increasingly being classified as a critical material as well.

For this reason, the **CLiMAFlux** project investigates how these critical materials can be eliminated through the use of alternative materials. Such changes in material selection inevitably require adaptations to the motor design, or at least to several of its subcomponents.

Within **CLiMAFlux**, rotors equipped with rare-earth permanent magnets are replaced by electrically excited rotors or by a combination of electrical excitation and non-rare-earth magnets, such as ferrites. In particular, this latter concept where electrical excitation is combined with permanent magnets in a hybrid excitation system, offers several advantages for electric vehicle applications. Unlike conventional PM-based machines, the magnetic flux is no longer fixed but can be actively controlled via the excitation current. This enables efficient operation at high speeds. In addition, the (non-rare-earth) magnets provide a bias magnetic flux, significantly improving efficiency under partial-load conditions on comparison the pure electrically excited motors. Beyond the hybrid excitation concept, **CLiMAFlux** also implements a brushless resonant energy transfer from the stator to the rotor excitation winding. The hybrid excitation system is studied in depth, and the rotor design is optimized and benchmarked against state-of-the-art axial flux motors with surface-mounted permanent magnets, both through simulations and experimental validation on two axial flux motor prototypes.

As an alternative to copper windings, the **CLiMAFlux** project also investigates the use of aluminum windings. Although the DC resistance of aluminum is significantly higher than that of copper, this disadvantage is largely mitigated at higher frequencies due to the reduced impact of skin and proximity effects. Moreover, aluminum is considerably lighter and less expensive than copper, and it can be recycled very easily. The motor design tools were adapted to accommodate aluminum windings, followed by a complete re-optimization of the overall AF motor design. This demonstrated that the gravimetric power density can be increased by approximately 10%. Here as well, two axial flux stator prototypes were manufactured and compared: one with conventional copper windings and one with aluminum windings.

In summary, the **CLiMAFlux** project has demonstrated the feasibility of axial flux motors that do not rely on critical materials.

TENNECO AUTOMOTIVE EUROPE B.V.
SINT-TRUIDEN, BELGIUM



ENVIRONMENTALLY FRIENDLY LUBRICANTS FOR SUSPENSION SYSTEM

In the framework of the EU Green Deal plan for a climate neutral EU by 2050, a search and review has been performed of suitable sustainable lubricants to replace the current mineral oil based fluid used in the AF motor and suspension system. Available potential fluids have been reviewed versus the requirements of the suspension system.

Several ecofriendly fluids are available for hydraulic applications, but it is important to firstly define the sustainability target you want to achieve, for instance carbon footprint reduction, biodegradable, bio-based, renewable, recyclable, toxicity.

Main categories of sustainable hydraulic fluids are **synthetic fluids** from which several can be bio-based (Synthetic esters, Polyalphaolefins, Synthetic hydrocarbons, Polyalkylene Glycol), **vegetable oils**, and **re-refined mineral oils** (recycled).

Mostly, blends of several base fluids and additives are proposed as a compromise between technical performance, cost and carbon footprint reduction.

For shock absorbers only very few sustainable fluids are available while several ecofriendly hydraulic liquids exist, but the latter are mainly for use in environmentally sensitive areas like forestry, marine, hydropower plants, earthmoving, construction, agriculture with a high biodegradability need.

For shock absorbers we defined the reduction of the CO₂ footprint of the fluid as the main sustainability target. For the electronic suspension system used in the **CLiMAFLUX** project, there is no ecofriendly lubricant on the market that complies with the specific high viscosity and high viscosity index specifications. For conventional shock absorbers some ecofriendly base fluids are available, but they need an adaption to achieve for instance viscosity specifications. These liquids have a low up to a very high carbon footprint reduction vs the current mineral oil based fluid. The highest carbon footprint reduction is obtained by using the highest content of bio based fluid and is combined with the highest cost.

For any suitable sustainable fluid, because of the different chemistry, extended validation is needed. This starts with critical material compatibility tests and execution of the functional tests of the shock absorber, the pump and the AF motor.

THE POLYTECHNIC UNIVERSITY OF TURIN
TURIN, ITALY



**Politecnico
di Torino**
International
University

PoliTO leads the Work Package on the optimal use and control of AF drive systems, focusing on the development of AI-enhanced controllers that simultaneously improve vehicle performance and passenger comfort. The approach leverages Neural Network (NN)-based digital twins to enable intelligent, adaptive, and high-performance control strategies.

An example of one of the developed controllers has been published in the article "Self-adaptive neural network model predictive anti-jerk control of electric powertrains", regarding proof-of-concept self-adaptive neural network model predictive control (SA-NNMPC) system, which uses a NN as main component of the prediction model, for the anti-jerk control of electric vehicles.

The proposed NNMPC algorithm outperforms two considered benchmarking anti-jerk controllers in nominal condition. Furthermore, during vehicle operation, the strategy integrates a real-time update mechanism of both the neural network prediction model and cost function weights so to be effective in handling changes of different nature, dealing with the variation of:

- i) the operating conditions w.r.t. those of the initial network training;
- ii) the main drivetrain and vehicle parameters; and
- iii) the whole vehicle altogether.

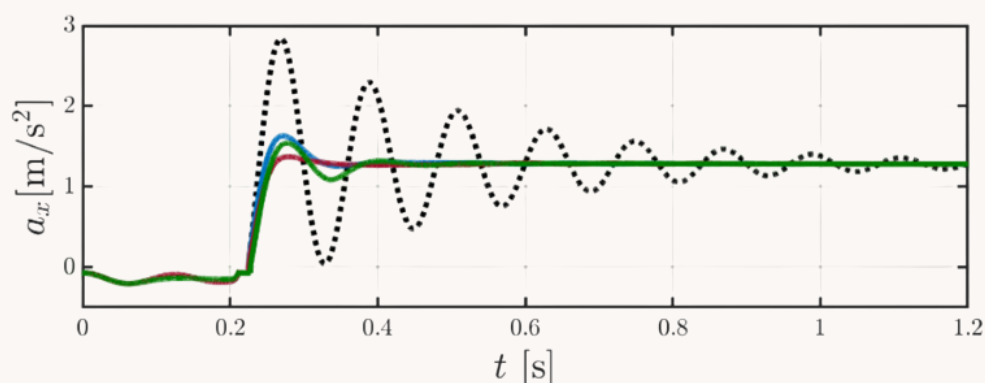
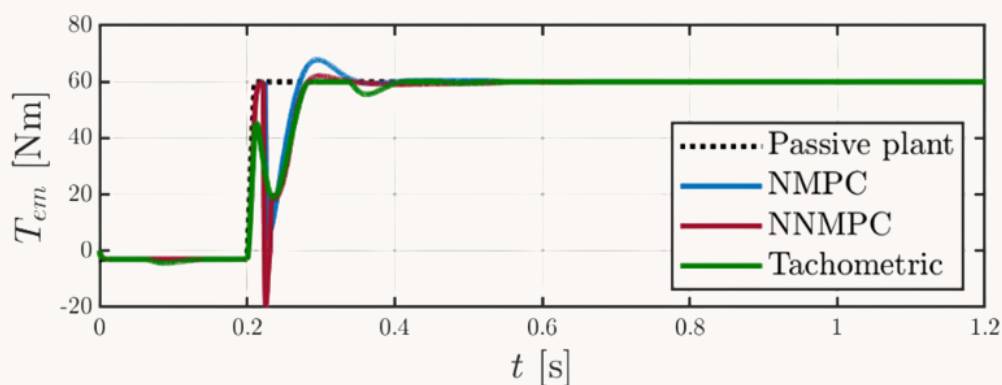

UNIVERSITY OF DEUSTO and
TENNECO INNOVACION SL
BASQUE REGION, SPAIN



Deusto

TENNECO

ACTIVE SUSPENSION CONTROLLER

Achieving a balance between ride comfort and handling performance remains one of the key challenges in modern vehicle dynamics. Passive suspension systems are simple and reliable; however, they cannot adapt to varying road conditions, inevitably leading to a compromise between comfort and stability. Semi-active systems offer improved performance by modulating damping forces, yet they still lack the ability to generate forces proactively in response to changing driving conditions. In contrast, active suspension systems are capable of producing control forces directly, enabling enhanced dynamic performance and allowing simultaneous improvement of both ride comfort and handling.

Controlling each motion independently may result in suboptimal performance, since roll and pitch dynamics are inherently coupled through vehicle mass distribution, suspension geometry, and load transfer effects. Therefore, high-performance active suspension systems require coordinated control strategies that explicitly account for this coupling. One effective approach is the use of a diagonally cross-connected configuration, in which the front-right actuator is linked to the rear-left, and vice versa. In such a setup, any generated control force simultaneously influences both roll and pitch motions.

To address this, a coupled roll–pitch control strategy is developed within the [CLIMAFLEX](#) project. The proposed approach ensures coordinated management of vehicle dynamics while maintaining overall system balance. The control architecture is implemented using PID control loops.

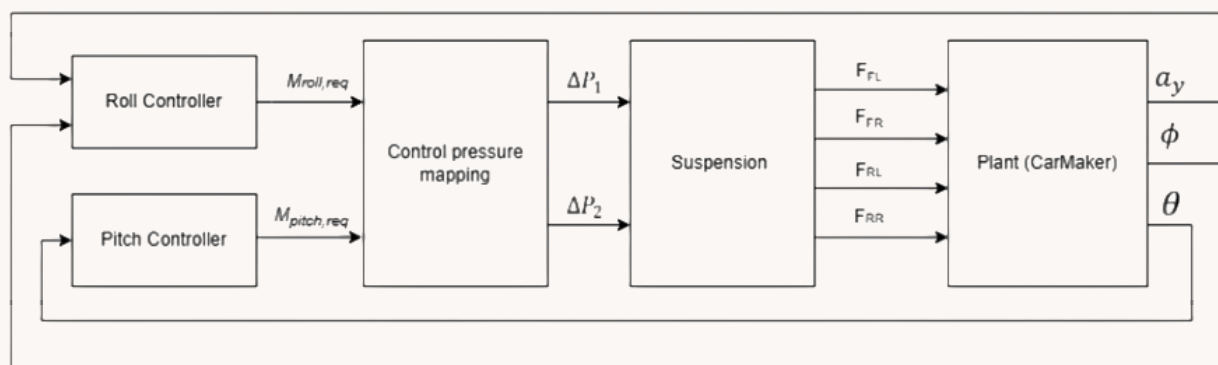

These controllers have been traditionally applied in nonlinear systems due to their simplicity, robustness, and model-free operation. PID control can stabilize and regulate nonlinear behavior around different operating points, effectively exploiting the local linear characteristics of the system. To further enhance performance across various driving scenarios, the PID parameters are optimized using genetic algorithms, allowing the controller to adapt to multiple operating conditions and achieve the desired compromise between ride comfort, handling, and stability.

AXIAL FLUX MOTOR TECHNOLOGY-BASED ACTUATORS FOR NEXT-GEN ELECTRIC VEHICLES

According to the International Energy Agency, over 17.3 million electric vehicles were produced globally in 2024, accounting for more than 20% of total vehicle production. The electrification of vehicles brings numerous architectural innovations, one of which is the so-called X-by-wire technology. This technology replaces traditional mechanical and hydraulic vehicle systems, such as steering, braking, and gear shifting, with electric actuators. As a result, integrated chassis control can be achieved, allowing all systems to operate optimally, which enhances safety and reduces energy consumption.

In the **CLIMAFLEX** project, we are developing reliable and cost-effective actuators that utilize less rare-earth material and are suitable for mass production.

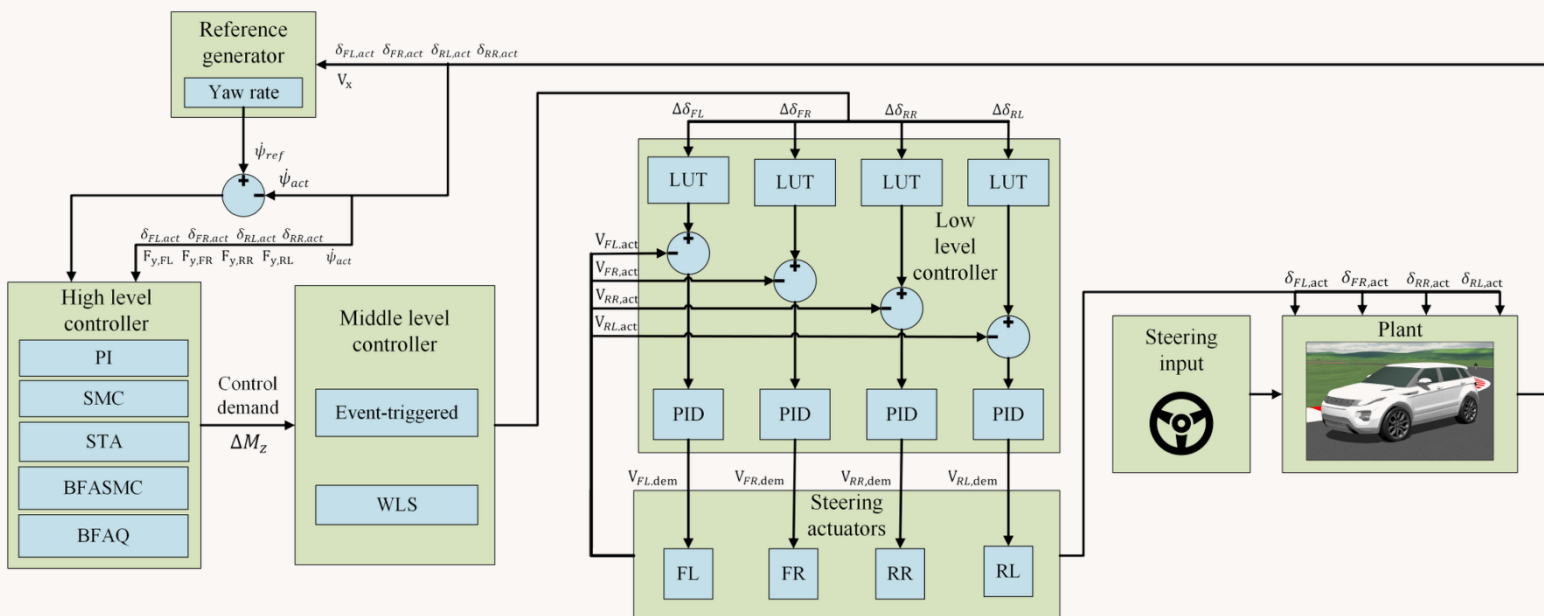

UNIVERSITY OF FLORENCE

FLORENCE, ITALY



UNIVERSITÀ
DEGLI STUDI
FIRENZE

PROMOTING SUSTAINABILITY IN ELECTRIC MOTOR DESIGN

As part of the **CliMAFlux** project, the University of Florence (UNIFI) is promoting a comprehensive approach to sustainability that goes beyond traditional impact assessment. Our goal is to integrate Circular Design paradigms directly into the design of next-generation electric motors. Although methods such as LCSA (Life Cycle Sustainability Assessment) are used to monitor environmental, social, and economic impacts, our strategy focuses on proactive design choices. As highlighted in our contribution to the AIAS 2024 conference «Development of Procedures for Disassembly of Industrial Products in Python Environment», we are developing, for example, metrics to specifically evaluate Design for Disassembly, ensuring that motors are built with their end of life already in mind.

More recently, contributions to the AIAS 2025 and SETC 2025 conferences «A Simulation Approach for the Impact Assessment of an Axial Flux Traction Motor Applied on Road Electric Vehicle» highlighted the importance of Design for Efficiency within Circular Design paradigms. Basically, UNIFI takes a holistic comparative approach. Break-even analyses are conducted that compare different production and disposal strategies based on their effects on the use phase. This ensures that an 'eco-friendly' production process does not compromise the operational efficiency of the motor. The ultimate goal is to translate these advanced methodologies into a practical decision support tool. This tool will enable **CliMAFlux** partners and designers to navigate complex trade-offs, allowing them to select design solutions that strike the perfect balance between high technical performance and long-term sustainability.

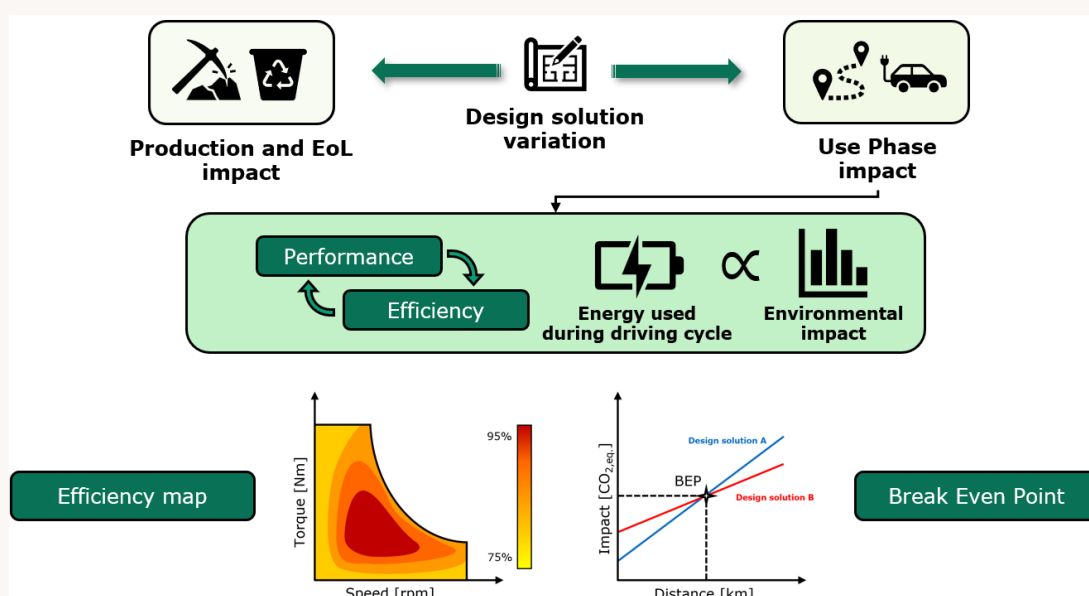

ILMENAU UNIVERSITY OF TECHNOLOGY
ILMENAU, GERMANY

The logo for Technische Universität Ilmenau, consisting of the lowercase letters "thi" in a teal, cursive font.

TECHNISCHE UNIVERSITÄT
ILMENAU

As part of the project, our organization is responsible for several technical tasks focusing on validation and assessment, suspension testing and the development of dedicated control strategies. To support these activities, a new class of test benches for different types of suspension actuators has been designed and implemented by our working group at Ilmenau University of Technology, specifically at the ThIMo II facility. The experimental procedures and testing campaigns conducted on this equipment will generate the data required to meet the project's technical objectives.

In addition, our organization leads Work Package 7 "Communication, dissemination & exploitation", which is dedicated to interaction activities with society. Within this work package, we have contributed to a range of outreach actions and participated in relevant events aimed at informing stakeholders and the wider public about the project's objectives and results. Project-related news and updates will continue to be shared via our LinkedIn Page [CliMAFlux - Horizon Europe Project](#).

We are also pleased to arrange the secondment for one of the project's partners – Maurizio Guadagno from UNIFI participates in the work processes in our organization.

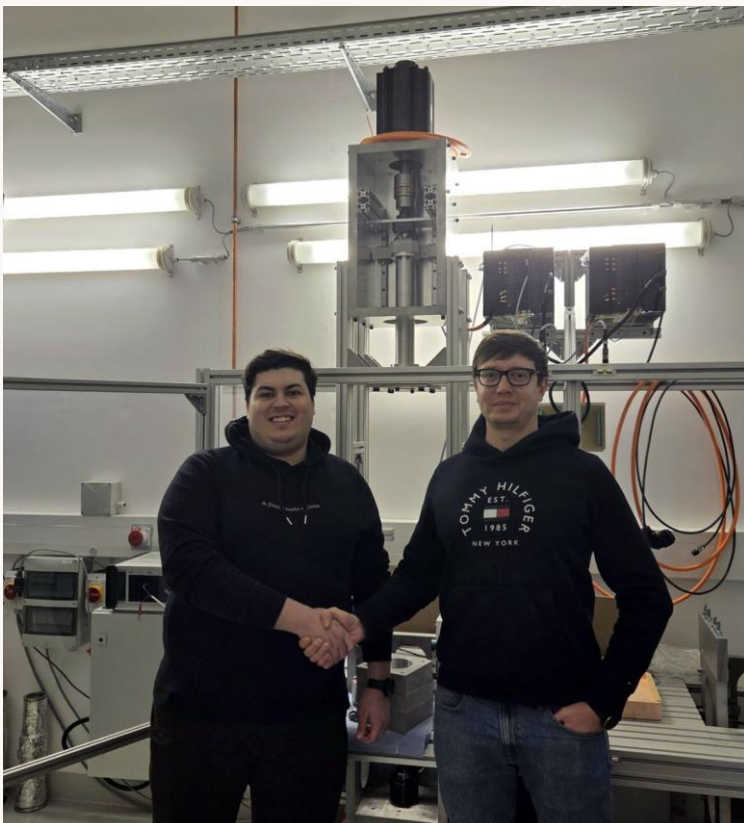

KEY EVENTS & HIGHLIGHTS

KICK-OFF MEETING – GHENT UNIVERSITY, 18-19 JANUARY 2024

GHENT, BELGIUM



The project officially kicked off with a two-day meeting organized by Ghent University, where consortium members got to know each other, discussed key points and the roadmap, and outlined actions for the work packages. Project adviser Joao Duarte Miranda was also present at the meeting.

CONSORTIUM MEETING 1 - TENNECO R&D CENTRE, 25-26 JUNE 2024

SINT-TRUIDEN, BELGIUM



Our first consortium meeting was marked by a visit to our industrial partner, Tenneco Automotive Europe B.V. At the meeting, we discussed preliminary results, ideas for implementation, and possible changes to the project. The participants visited the production facilities and observed the development and assembly of parts for car suspension systems.

CONSORTIUM MEETING 2 – TRAXIAL BV, 14-15 JANUARY 2025 KORTRIJK, BELGIUM

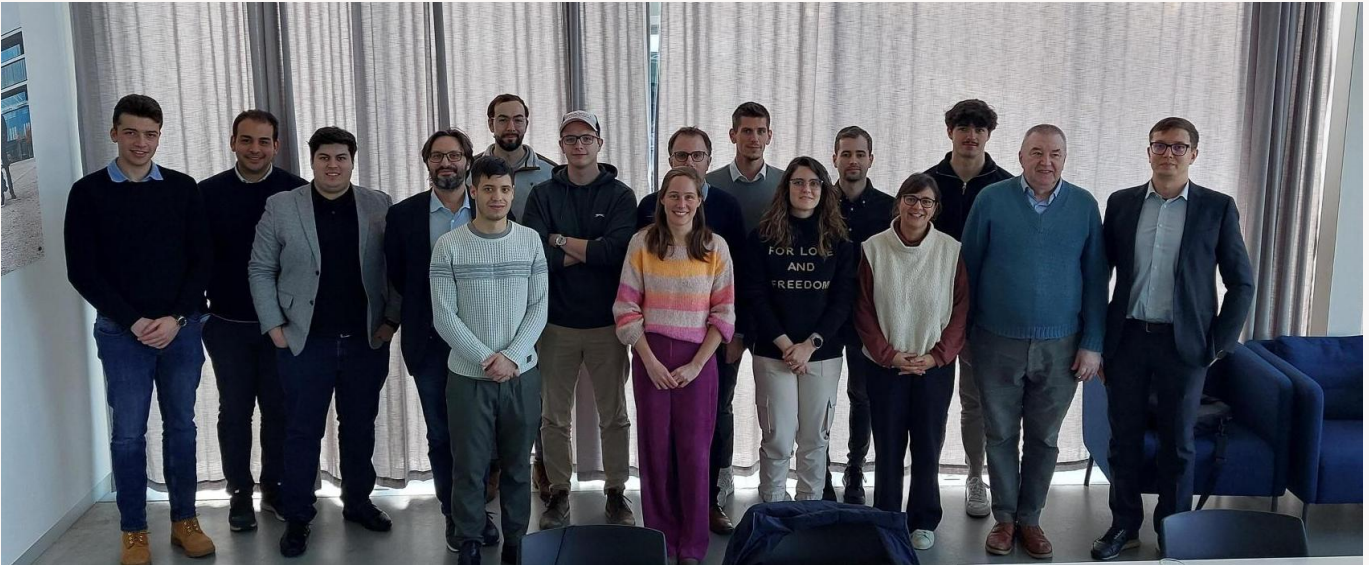

The meeting on the territory of our key industrial partner, besides to a general discussion of the results and updates, allowed us to identify the development vectors between other partners in two main areas - the development of the Integrated drive unit and the AF actuator for suspension system. In addition to fruitful discussions, all participants of the meeting visited the Research center and Production facilities.

CONSORTIUM MEETING 3 - UNIVERSITY OF FLORENCE, 18-19 JUNE 2025 FLORENCE, ITALY



At this mid-project consortium meeting, current results and implementation strategies were discussed, while partners reviewed progress across all work packages, defined priorities and next steps, and strengthened collaboration and coordination. The meeting proved effective in aligning milestones, addressing challenges, and reinforcing the overall project direction.

CONSORTIUM MEETING 4 – POLITECNICO DI TORINO, 28 JANUARY 2026 TURIN, ITALY



During this Consortium Meeting, partners reviewed project progress, highlighted key achievements, and identified areas requiring further attention, while defining concrete next steps toward project goals, including plans for the final configuration and testing of the Integrated Drive Unit, as well as controller development and system modeling. Participants presented recent developments and innovative ideas, made several important decisions, and complemented the meeting with a visit to a thematic exhibition.

PRESENTATION AT TRANSBALTICA BY VIKTOR SKRICKIJ (VILNUSTECH)



“In the [CLIMAFLEX - Horizon Europe Project](#), we will develop chassis auxiliary systems using axial flux motor technology to overcome those limits — and implement a digital twin concept that is expected to halve task completion time. Excited for the next steps and the impact this will bring.”

PRESENTATION AT 54TH ITALIAN SCIENTIFIC SOCIETY OF MECHANICAL ENGINEERING DESIGN (AIAS 2025) BY MAURIZIO GUADAGNO (UNIFI)

The scientific paper “Modeling and Simulation of Active Suspension System for Road Vehicles and Sensitivity to Design Criteria for Energy Efficiency” was presented.

This research and development enhances the scientific component of the project and helps to achieve the set goals and objectives.

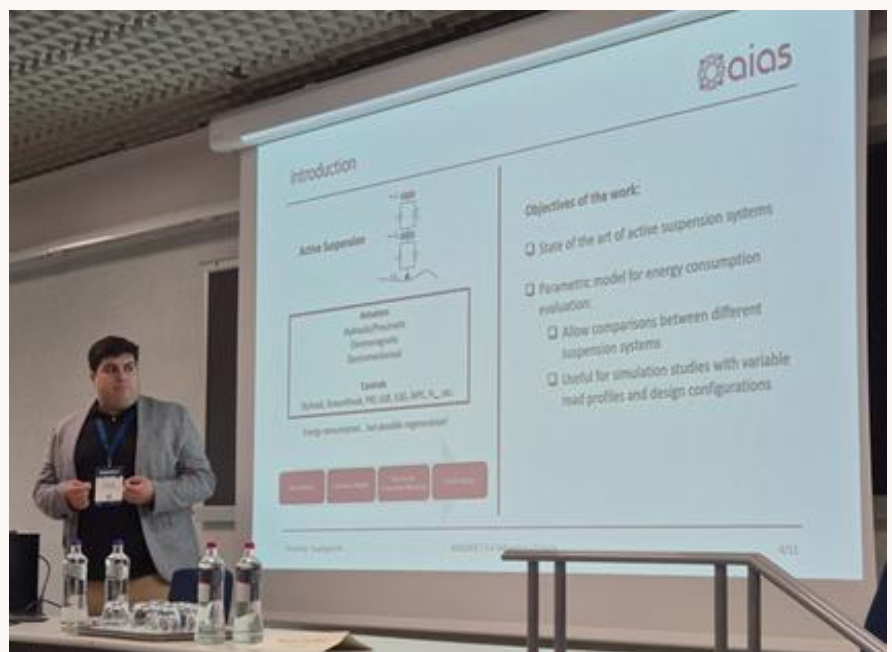

DISSEMINATION AND COMMUNICATION ACTIVITIES



PRESENTATION AT IECON2025 BY HENDRIK VANSOMPEL (UGENT) AND VALENTIN IVANOV (TU ILMENAU)



“Trend that caught our eye: the growing momentum around electrically excited machines—which are also an active research topic within **CLIMAFLEX**, aligning well with our mission to push the boundaries of efficiency, scalability, and supply chain security.”

POSTER PRESENTATION AT SCIENCE FORUM OF TU ILMENAU BY ROMAN TANGALYCHEV (TU ILMENAU)

The event provided an excellent opportunity to present the project’s goals and key results to a broad audience, as well as to engage in meaningful discussions on relevant topics with representatives from both academia and industry.

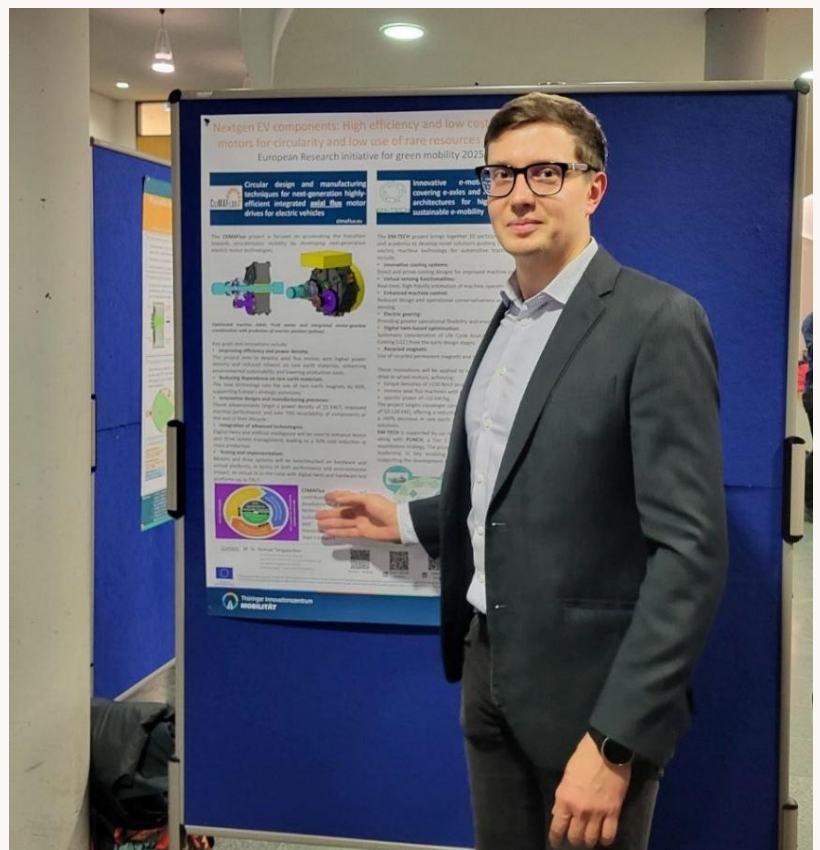

Read about our work in

- Guadagno, M.; Innocenti, E.; Berzi, L.; Corsi, S.; Delogu, M. Development of Procedures for Disassembly of Industrial Products in Python Environment. Eng. Proc. 2025, 85, 6. <https://doi.org/10.3390/engproc2025085006>
- Guadagno, M., Berzi, L., Pugi, L., and Delogu, M., "A Simulation Approach for the Impact Assessment of an Axial Flux Traction Motor Applied on Road Electric Vehicle," SAE Technical Paper 2025-32-0077, 2025, <https://doi.org/10.4271/2025-32-0077>.
- Frison, G.; Alberti, F.; Ciravegna, L.; Dimauro, L.; Sorniotti, A. Self-Adaptive Neural Network Model Predictive Anti-Jerk Control of Electric Powertrains. Mechanism and Machine Theory 2025, 214, 106082. <https://doi.org/10.1016/j.mechmachtheory.2025.106082>

Or let's have a chat at these upcoming conferences

- Presentation by Maurizio Guadagno (UNIFI) at "CO2 Reduction for Transportation Systems Conference – The road to decarbonization"; June 9-10, 2026 in Turin, Italy.
- Special session Towards Sustainable Electrical Machines: From Materials and Design to Circularity and Life-Cycle Impact at "International Conference on Electrical Machines (ICEM2026)"; September 6-9, 2026 in Funchal, Madeira, Portugal.
- Special session submitted for "IEEE Vehicle Power and Propulsion (IEEE VPPC 2026)"; 5-9 October, 2026 in Lyon, France.

Feel free to contact us via the [CLIMAFLEX website](#) or [LinkedIn](#).